



Features

- High resistance to wear.
- Quiet running.
- High resistance to dirt & moisture.
- Tolerances adjustable.
- High resistance to corrosion.
- Ability to take high loads & moments in all directions.
- Low weight.
- Ability to take shock loadings and vibrations against blows and vibrations.

Specification

Model	MCRPLS			
Acting type	Double acting			
Tube I.D. (mm)	32	40	50	63
Port size	G1/4			G3/8
No. of port	3			
Medium	Air			
Operating pressure range	0.1~0.78 MPa			
Stroke range	100~5700mm (*1)			
Ambient temperature	-10~+55°C (No freezing)			
Lubrication	With or without lubrication			
Cushion	With adjustable cushion at both ends			
Sensor switch	RCAL (Please refer to page 6-9)			
Sensor switch holder	HPL			

*1. In increments of 1mm, long strokes on request.

*2. The tube isn't airtight, so the cylinder is allowed the leakage.

Before the cylinder is sale, it has passed the standard of leakage test.

Order example

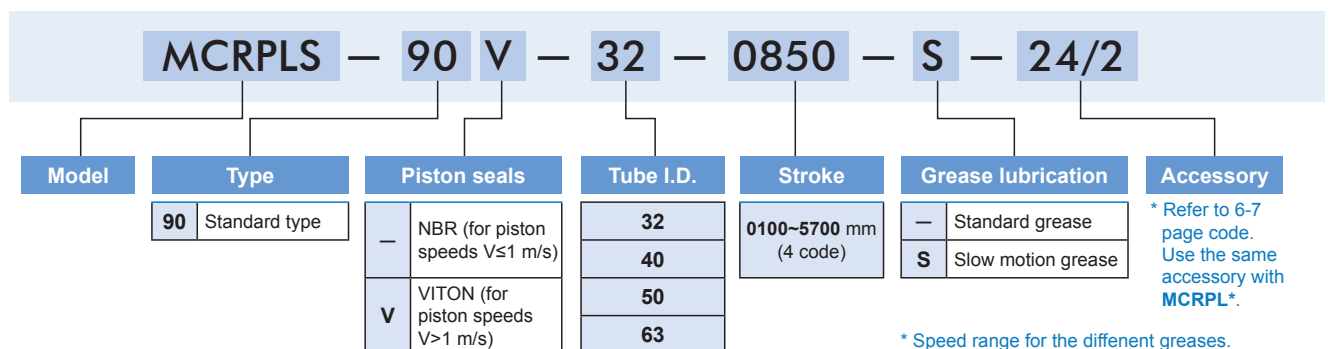

* Speed range for the different greases.

• Standard grease

NBR piston seals: $0.2 \text{ m/s} \leq V \leq 1 \text{ m/s}$
 VITON piston seals: $1 \text{ m/s} < V$

• Slow motion grease

NBR piston seals: $V < 0.2 \text{ m/s}$
 VITON piston seals: $V < 0.2 \text{ m/s}$

Forces and moments

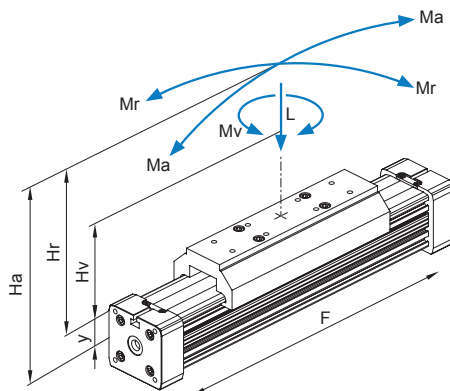

Formulas

$$Ma = F \times Ha$$

$$Mr = F \times Hr$$

$$Mv = F \times Hv$$

Cylinder \varnothing	Effect force (N) 0.6 MPa	zul. Last max. (N)	La, Lr, Lv max (N)	Ma max. (Nm)	Mr max. (Nm)	Mv max. (Nm)
32	420	495	495	39	15	39
40	640	825	825	99	35	99
50	1000	1320	1320	170	58	170
63	1550	1815	1815	315	105	317

- The above mentioned moments (Ma max, Mr max, Mv max) are related to the guide rail center. The load force (L) is the summary of all single forces related to the common center of the mass. The center of the mass can be placed inside or outside the surface area of the carriage.
- Normally the carriage would experience a dynamic load, which has to be considered with the calculation of needed piston force (F) and capacity of the guided system. Use the following calculation formula.

$$\frac{Ma}{Ma \text{ max}} + \frac{Mr}{Mr \text{ max}} + \frac{Mv}{Mv \text{ max}} + \frac{L}{L \text{ max}} \leq 1$$

Deflection diagram

- Max. distance (SL) in m – for $\varnothing 32$ –63mm

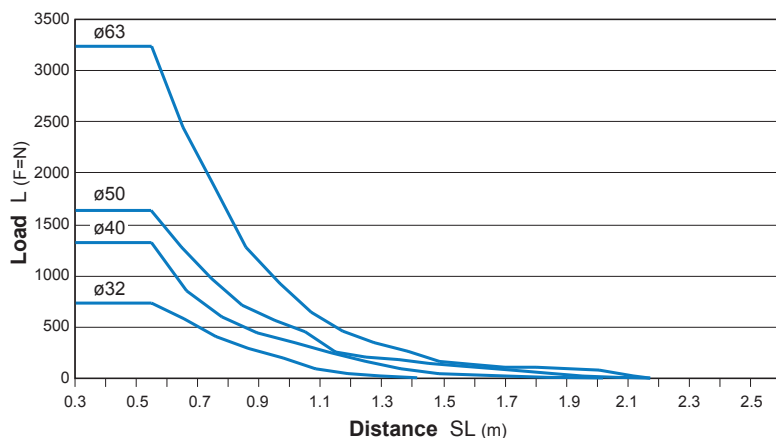
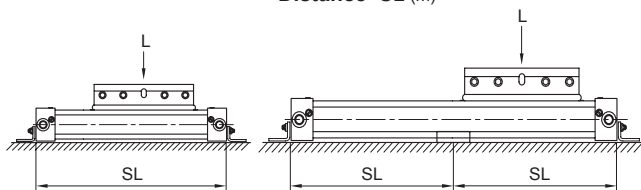
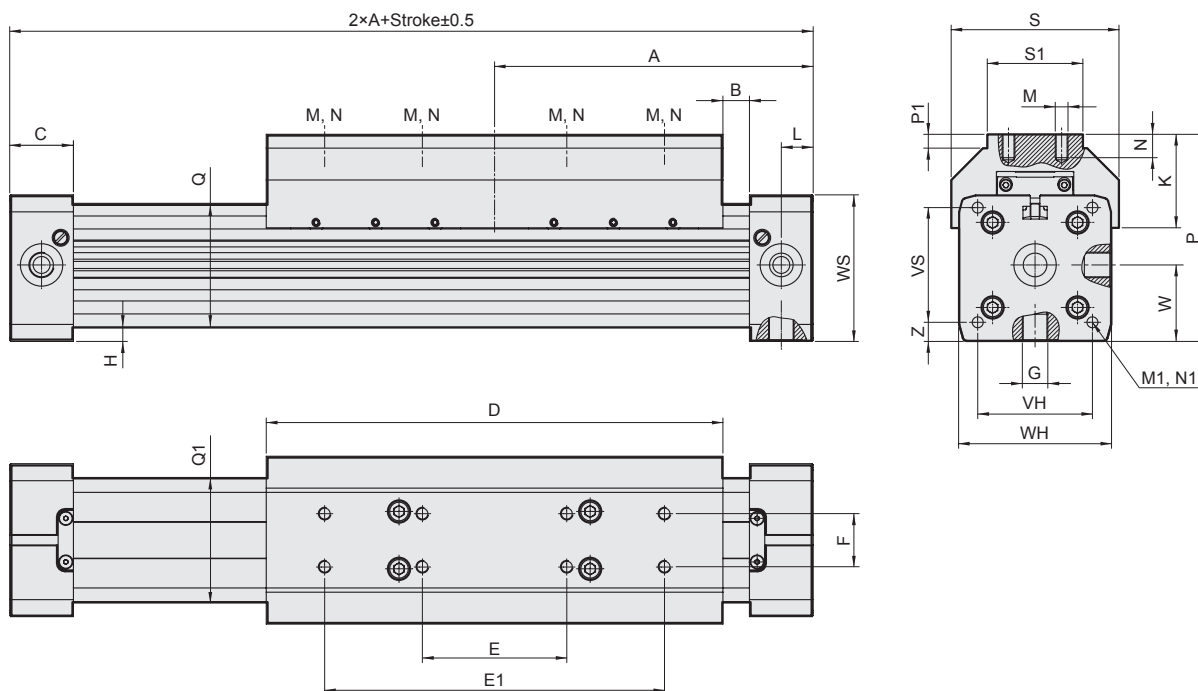

Diagram information

- Calculated deflections without support of 0.5~1 mm allow exceeding of supporting distance.
- Calculated deflections without support of 1 mm ~ max. 1.5 mm require reduction of the supporting distance.





Code Tube I.D.	A	B	C	D	E	E1	F	G	H	K	L	M	N	M1	N1
32	125	22.0	27	152	60	120	25	1/4	2.0	42.5	10.5	M5	10	M6	14
40	150	12.5	30	215	68	160	25	1/4	7.0	44.0	15.0	M8	10	M6	17
50	175	17.5	33	250	84	190	25	1/4	0.5	48.5	11.7	M8	10	M6	18
63	215	6.5	55	320	120	240	25	3/8	1.5	56.0	25.0	M8	14	M8	18

Code Tube I.D.	P	P1	Q×Q1	S	S1	VH	VS	W	WH	WS	Z
32	81.5	6.5	52×51	66	40	36	40	30.0	52	56	8.0
40	97.5	6.5	58.5×59	79	45	54	54	36.0	72	69	9.0
50	110.0	6.5	77×78	92	50	70	70	43.5	80	80	4.0
63	137.0	5.0	102×102	116	50	78	78	62.5	106	106	14.5